

## INSTRUCTIONS FOR USE

### EQUIPMENT

- Personal Protection Equipment (not supplied by SeaShield)
- Surface Preparation Equipment (not supplied by SeaShield)
- Cutting tool (not supplied by SeaShield)
- Denso Paste S105™
- SeaShield™ Marine Piling Tape
- Densyl™ Mastic, Denso Profiling Mastic™ or other mastic as specified by Denso (as required)
- Denso™ Glass Outerwrap (GOW) (as required)
- Denso™ Clear Outerwrap (as required)
- Bitumen Outerwrap (as required)
- Denso Perforation Tools (as required)
- Denso™ PVC Self-Adhesive Tape (as required)

### HANDLING AND STORAGE

- All materials shall be stored upright in their original packaging, out of direct sunlight.
- All materials shall be stored in a cool dry place between 5°C and 35°C – (Note standard grades of Bitumen Outerwrap shall be stored between 5°C and 20°C).
- Denso GOW shall remain in its foil pouches until required for use. Foil pouches must not be punctured prior to use.
- All tools shall be stored in their original packaging, in a cool dry place out of direct sunlight between 5°C and 35°C.
- Please read the Safety Data Sheet for all materials before commencing application.

### DISPOSAL

Please minimise or avoid waste wherever possible. Please do not discard waste material, including packaging, in the surrounding environment. Follow all relevant legislation for disposal.

#### IMPORTANT:

Winn & Coales (Denso) Ltd pursue a policy to develop and continually improve all of our products and therefore information given in this data sheet is intended as a general guide and does not constitute a warranty, specification or risk assessment. These guidelines may not cover all circumstances; however, our sales personnel are committed to assisting the user in establishing the suitability of the product for its intended purpose and additional specific information, including Safety Data Sheets, is available on request. We recommend that installation is carried out with due regard to Health and Safety and in accordance with relevant local statutes and regulations. Any conflict between these guidelines and the specific project specifications must be resolved by the user before work commences. All rights reserved.

**SURFACE PREPARATION****METHODS AND EQUIPMENT**

The following methods may be used:

- Hand tool cleaning.
- Power tool cleaning.
- High pressure water jetting.
- Abrasive blast cleaning.
- Other methods by agreement.

The following shall be considered:

- The degree of marine growth on the pile or bracing.
- The degree of corrosion on the pile or bracing.
- Any existing corrosion prevention coatings on the pile or bracing.
- Any hot working or spark restrictions at the site.
- Any environmental restrictions at the site.
- The reduction of debris being deposited into the marine environment.
- Any other considerations specific to the site.

**DEGREE OF CLEANING****Metal:**

- All loose corrosion products must be removed.
- All mill scale must be removed.
- Protrusions must be ground smooth to remove sharp edges and sudden changes of profile. Care shall be taken to avoid damage to the weld seam.

**Concrete:**

- All loose concrete must be removed.
- All concrete laitance must be removed.
- Protrusions must be ground smooth to remove sharp edges and sudden changes of profile.

**Existing corrosion prevention coatings:**

- All loose corrosion prevention coatings must be removed.
- Tightly adhering corrosion prevention coatings can remain on the surface of the pile or bracing.

**Marine growth:**

All living marine growth must be removed. Marine biofilm can establish on the surface of the pile or bracing within 24 hours. Groups of piles and/or bracings may have heavy levels of marine growth and other contamination removed as a "batch". If that "batch" of piles and/or bracings is then not wrapped with a SeaShield system within 24 hours, it is required as a minimum to wire brush the surface of the piles or bracings to remove any biofilm that may have formed.

Non-living, tightly adhering mineral deposits caused by shellfish or similar can remain on the surface of the pile or bracing.

The surface of the pile or bracing can be washed with seawater as required to aid in achieving the above requirements.

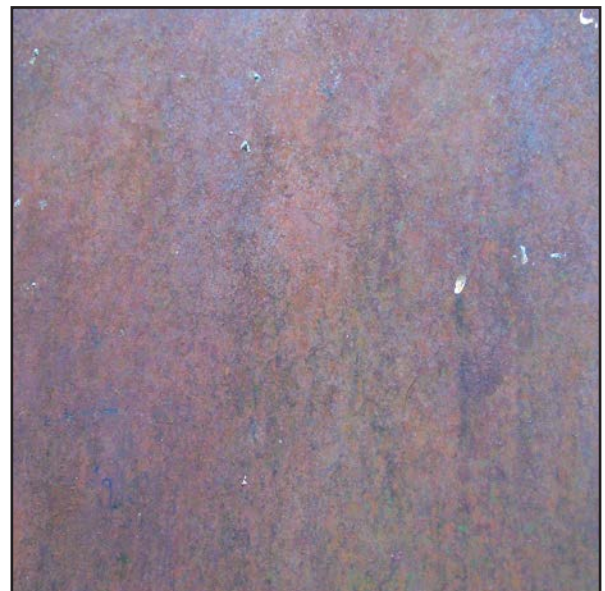

Example image of an acceptable level of surface preparation.

CORROSION CONTROL FOR MARINE STRUCTURES  
(INCLUDING PILES, BRACINGS, SUPPORTS, OR SIMILAR)



Example image of a pile featuring loose corrosion that would require removal.



Example image of a pile featuring a loosely adhering corrosion prevention coating that would require removal.



Example image showing tightly adhering corrosion prevention coating and corrosion (orange rust) that would **not** require removal.

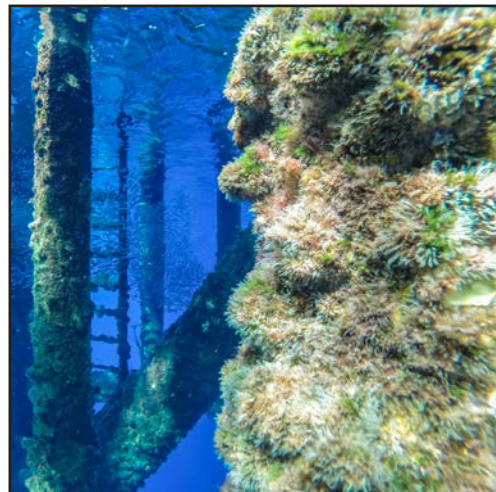

Example image of marine growth.



Example image of marine biofilm.



Example image of a pile featuring acceptable levels of non-living, tightly adhering mineral deposits.

**PASTE S105 APPLICATION****DEEP PITS**

A deep pit is defined as a pit of 2.0mm or greater, where there is a risk that the Marine Piling Tape will 'bridge' the pit, creating a void. These pits shall be filled with Paste S105 to prevent there being a void (see Fig. 1).

Should there be a very deep pit, or should it be otherwise difficult to fill a deep pit with Paste S105, a thin film of Paste S105 shall be applied into the pit followed by a patch of Marine Piling Tape which shall be pressed firmly into the pit to prevent there being a void (see Fig. 2).

Paste S105 can be applied by various means to fill deep pits such as, flexible filling knife, trowel, gloved hand, roller, brush, or other means as agreed.

**LARGE WELD BEAD**

A large weld bead is defined as a weld bead of 2.0mm height or greater, where there is a risk that the Marine Piling Tape will 'bridge' the weld bead, creating a void.

Paste S105 shall be applied along either side of a weld bead, to prevent there being a void (see Fig. 3).

**GENERAL PRIMING**

Paste S105 shall be used as a general primer on the pile or bracing. A thin layer of Paste S105 shall be applied over the area for protection. Paste S105 can be applied by various means to act as a primer such as, gloved hand, roller, brush, or other means as agreed.

The purpose of Paste S105 as a primer is to assist with displacement of water from the surface of the pile. There is no minimum requirement for the thickness of the Paste S105 layer. A thick layer of Paste S105 is not recommended or required.

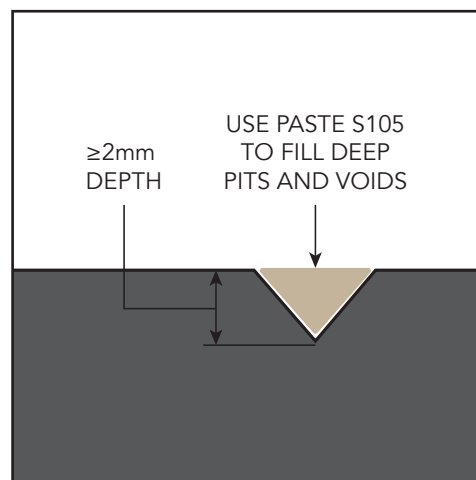

Fig. 1: Filling deep pits of 2.0mm, or greater, depth.

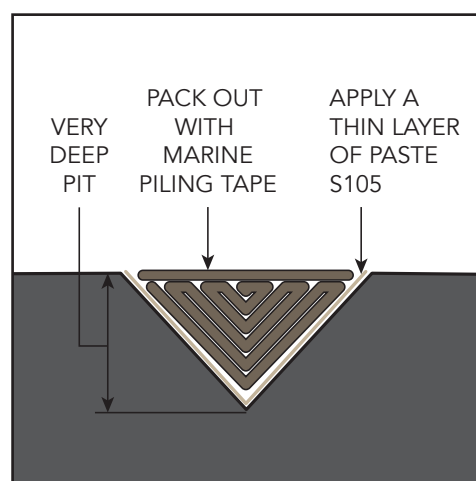

Fig. 2: Filling very deep pits.

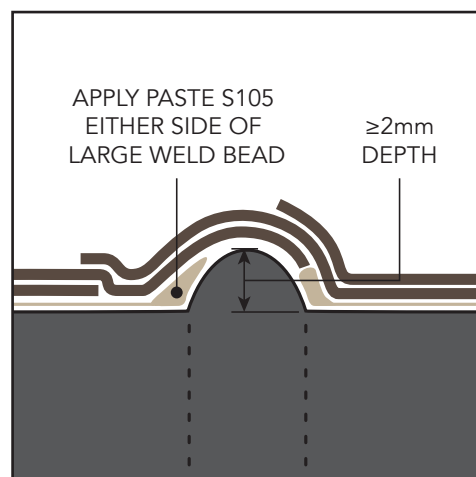
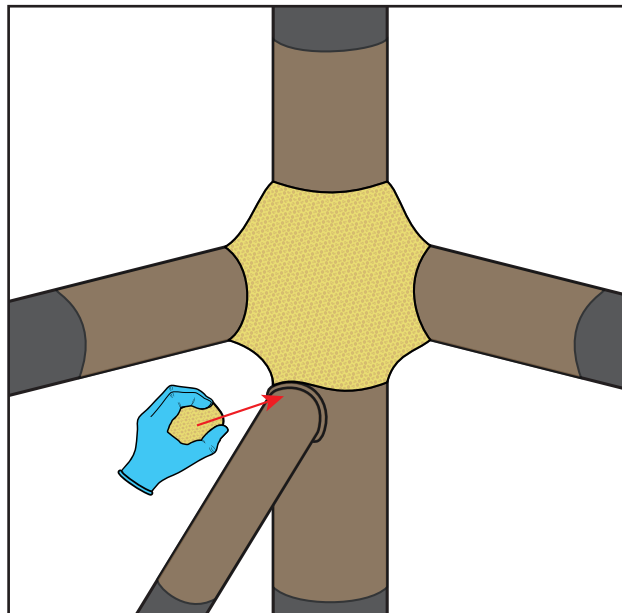

Fig. 3: Large weld beads.

**MASTIC APPLICATION**

Areas where bracings meet the pile may require profiling with Mastic. These areas shall be profiled as required to prevent bridging of the subsequent tape wrapping.

Where possible, the angle shall be less than 45° to provide a shallow angle for tape wrapping.



**Fig. 4:** Mastic application to the pile and bracings to create a smooth profile for tape wrapping.

## MARINE PILING TAPE APPLICATION

The Marine Piling Tape shall be applied with the correct side facing the pile or bracing. This will mean that the backing film, which is not removed, is the side that faces away from the pile or bracing surface (see Fig. 5). The Marine Piling Tape, together with the Paste S105 forms the primary corrosion prevention layer. The Marine Piling Tape must be in contact with the surface of the pile or bracing or where required, the Mastic at any point within the area for protection.

The wrapping shall start with strips of Marine Piling Tape applied around the pile and bracings as required depending on the number and orientation of bracings (see Fig. 6 and Fig. 7). The remaining lengths of pile and bracings shall then be wrapped, starting with 2 full circumferential wraps of the Marine Piling Tape (see Fig. 8). The wrapping shall then proceed spirally at a 55% overlap. The wrapping shall finish with 2 full circumferential wraps of the Marine Piling Tape. There shall be a minimum of 2 layers of Marine Piling Tape at any point in the area for protection.

To ensure continuity of multiple systems, if another SeaShield System shall be applied to the pipe in addition to the SeaShield 70/80 System, the Marine Piling Tape shall extend onto the pipe either:

- Fully, should the other SeaShield System be completely applied within the work shift;

OR

- Partially, to enable additional Marine Piling Tape to overlap a minimum of 100mm onto the existing Marine Piling Tape in a future work shift.

A new roll of Marine Piling Tape shall overlap onto the previous roll by the width of the roll. For example, if the roll is 300mm wide then the overlap shall be 300mm (see Fig. 5).

The Marine Piling Tape shall be smoothed into position as it is wrapped around the pile or bracing. If required the Marine Piling Tape may be cut to prevent bridging and assist in smoothing. If this is done it must be ensured that there is still a minimum of 2 layers of Marine Piling Tape in that area and under no circumstances shall the pile or bracing surface be exposed.

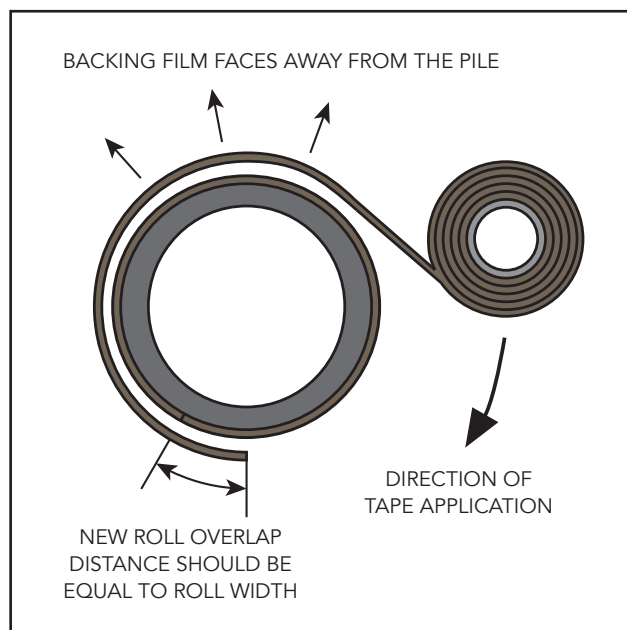

Fig. 5: Correct tape application procedure.

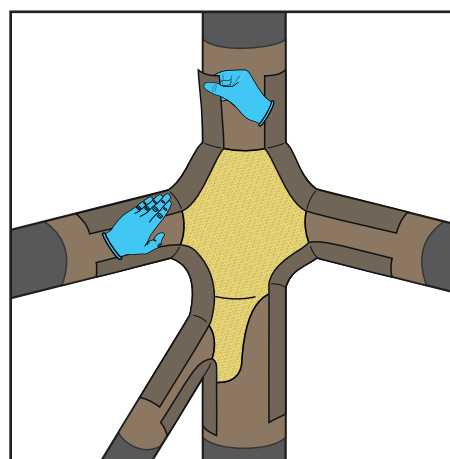

Fig. 6: Strips of Marine Piling Tape are applied to the pile and bracings as required.

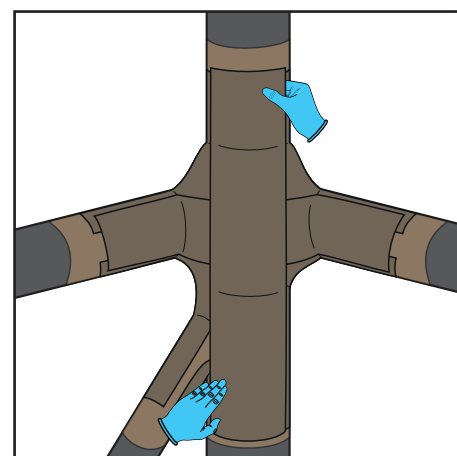
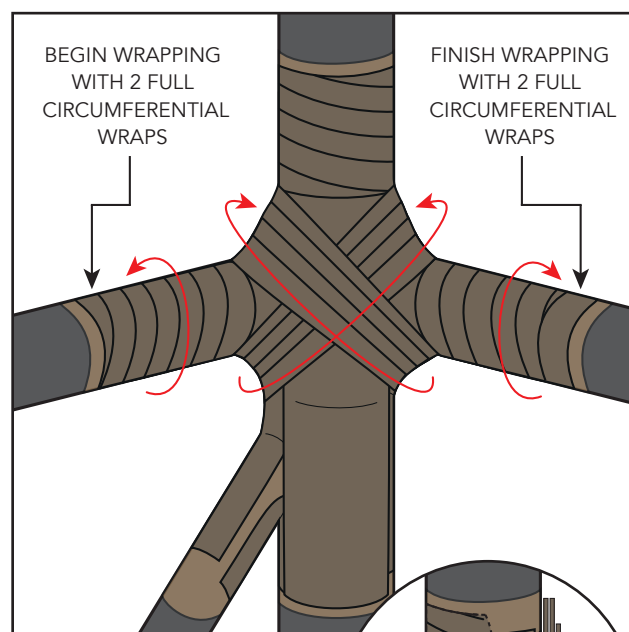

Fig. 7: A suitable width of Marine Piling Tape is applied along the length of the inner section of the node. Repeat on the outer straight section.

**CORROSION CONTROL FOR MARINE STRUCTURES**  
(INCLUDING PILES, BRACINGS, SUPPORTS, OR SIMILAR)

It is recommended to minimise the amount of time the Marine Piling Tape is exposed to the marine environment. The Marine Piling Tape shall not be left exposed to the marine environment beyond the end of a work shift. Prolonged exposure of the Marine Piling Tape to the tidal, wind and wave conditions of the marine environment may result in damage to the Marine Piling Tape. Should the Marine Piling Tape be exposed to the marine environment for a prolonged length of time it shall be inspected for damage and any damage shall be repaired as described within the relevant Maintenance and Repair document.



**Fig. 8:** Application of Marine Piling Tape to the rest of the pile and bracings with a 55% overlap (sectional view inset).

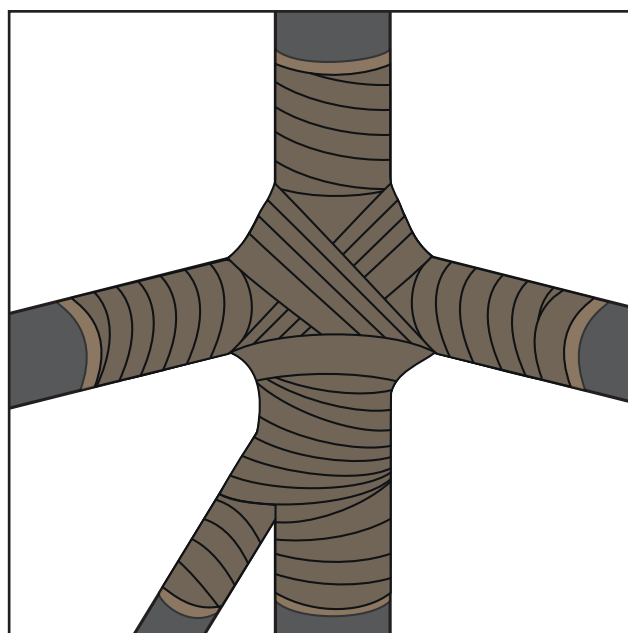

**Fig. 9:** Completed Marine Piling Tape application with a minimum of two layers of tape in all areas to be protected.

## BITUMEN OUTERWRAP APPLICATION

The Bitumen Outerwrap may not be required. If it is not specified, then the following instructions can be ignored.

The Bitumen Outerwrap shall extend a minimum of 100mm beyond the ends of the Marine Piling Tape (see Fig. 11) unless the SeaShield 70/80 System is being used in combination with another SeaShield System (see Fig 17).

The Bitumen Outerwrap is manufactured with an interleaving. This interleaving shall be removed during application (see Fig. 10). The interleaving shall be peeled back to expose approximately 100mm of the bitumen adhesive. The exposed adhesive shall be pressed firmly onto the pile surface and Marine Piling Tape to secure it in position.

The Bitumen Outerwrap shall be applied in a similar manner to the Marine Piling Tape (see Figs. 6-9). The wrapping shall start with strips of Bitumen Outerwrap applied around the pile and bracings as required depending on the number and orientation of bracings. The remaining lengths of pile and bracings shall then be wrapped, starting with 2 full circumferential wraps of the Bitumen Outerwrap. The wrapping shall then proceed spirally at a 55% overlap. The wrapping shall finish with 2 full circumferential wraps of the Bitumen Outerwrap. There shall be a minimum of 2 layers of Bitumen Outerwrap at any point in the area for protection.

A new roll of Bitumen Outerwrap shall overlap onto the previous roll by the width of the roll. For example, if the roll is 300mm wide then the overlap shall be 300mm (see Fig. 10).

During wrapping the Bitumen Outerwrap shall be smoothed by hand to exclude water, air bubbles and wrinkles from under the tape. If required the Bitumen Outerwrap may be cut to prevent bridging and assist in smoothing. If this is done it must be ensured that there is still a minimum of 2 layers of Bitumen Outerwrap in that area and under no circumstances shall the Marine Piling Tape be exposed.

The Bitumen Outerwrap shall be inspected to ensure it has been wrapped with the specified 55% overlap, that large air bubbles (greater than 25mm across) are excluded from under the Bitumen Outerwrap and that all overlaps are sealed together.

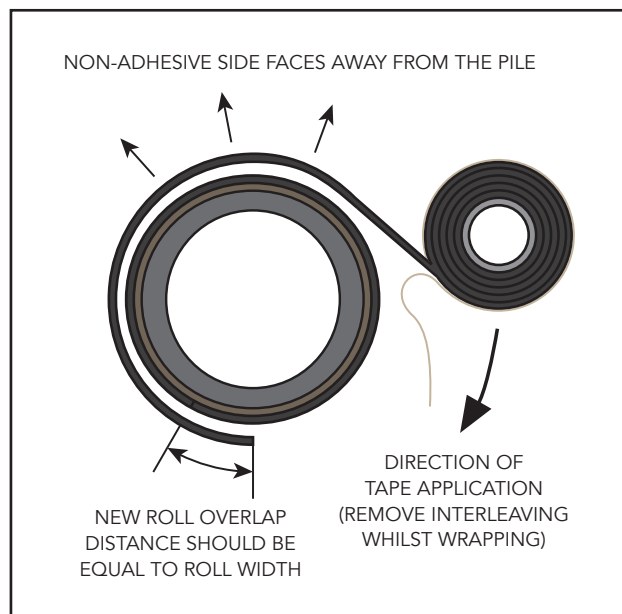

Fig. 10: Correct tape application procedure.

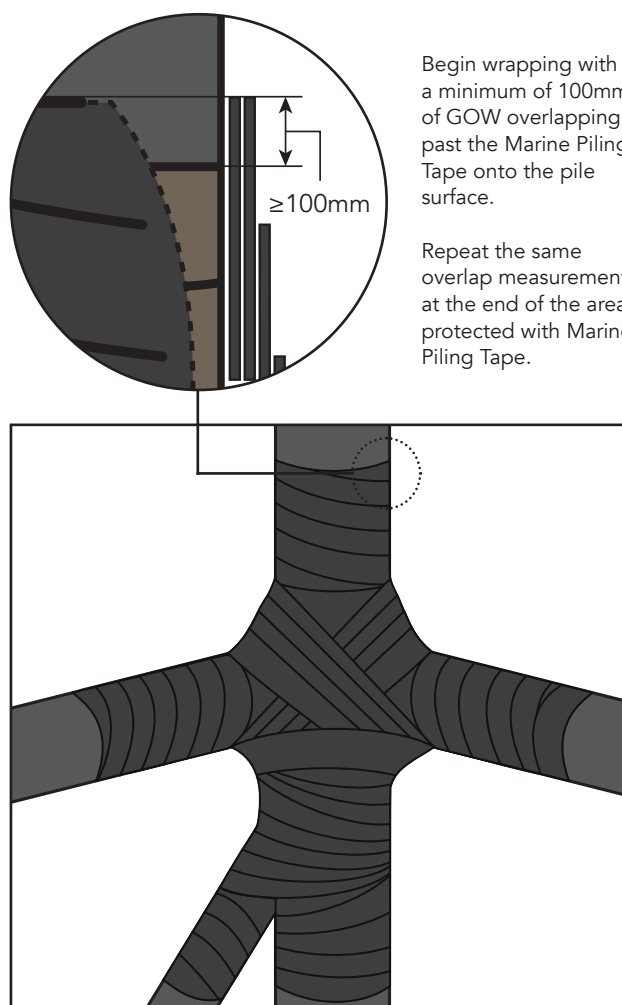
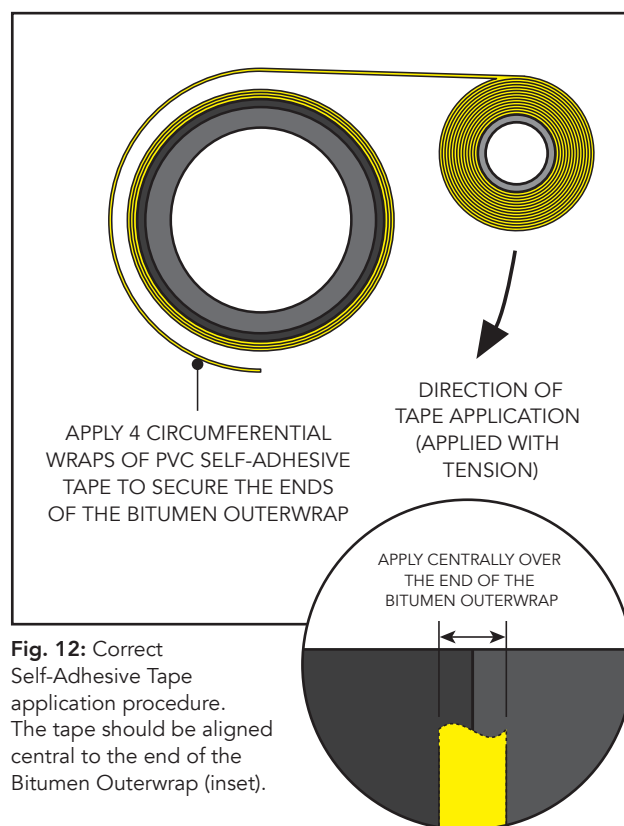

Fig. 11: Completed Bitumen Outerwrap application.



Secure the end of the Bitumen Outerwrap by applying 4 circumferential wraps of PVC Self-Adhesive Tape (see Fig. 12). If the Bitumen Outerwrap shall be overwrapped with Glass Outerwrap (GOW) then it is not required to secure the ends of the Bitumen Outerwrap with PVC Self-Adhesive Tape.



## GLASS OUTERWRAP (GOW) APPLICATION

The Glass Outerwrap (GOW) may not be required. If it is not specified, then the following instructions can be ignored.

The GOW shall extend a minimum of 100mm beyond the ends of the Marine Piling Tape or Bitumen Outerwrap (see Fig. 14), unless the SeaShield 70/80 System is being used in combination with another SeaShield System (see Fig 17).

The GOW is packaged in a foil pouch to protect it from moisture. Moisture will initiate the curing process so the foil pouch shall not be opened until the GOW is to be applied. Before application, the foil pouch containing the GOW shall be manipulated by hand to ensure that the resin is evenly distributed through the carrier cloth.

The foil pouch shall be opened by hand or using a bladed tool. The GOW roll shall be immersed in clean water (sea water is acceptable) for up to 1 minute to initiate the curing process. The curing process will be shortened at higher temperatures and this should be considered when determining the amount of time the roll is immersed in water.

The GOW shall be applied in a similar manner to the Marine Piling Tape and Bitumen Outerwrap (see Figs. 6-9). The wrapping shall start with strips of GOW applied around the pile and bracings as required depending on the number and orientation of bracings. The remaining lengths of pile and bracings shall then be wrapped, starting with 2 full circumferential wraps of the GOW. The wrapping shall then proceed spirally at a 55% overlap. The wrapping shall finish with 2 full circumferential wraps of the GOW. There shall be a minimum of 2 layers of GOW at any point in the area for protection.

A new roll of GOW shall overlap onto the previous roll by the width of the roll. For example, if the roll is 300mm wide then the overlap shall be 300mm (see Fig. 13).

During wrapping the GOW shall be smoothed by hand to exclude water, air bubbles and wrinkles from under the tape. If required the GOW may be cut to prevent bridging and assist in smoothing. If this is done it must be ensured that there is still a minimum of 2 layer of GOW in that area and under no circumstances shall the Marine Piling Tape or Bitumen Outerwrap be exposed.

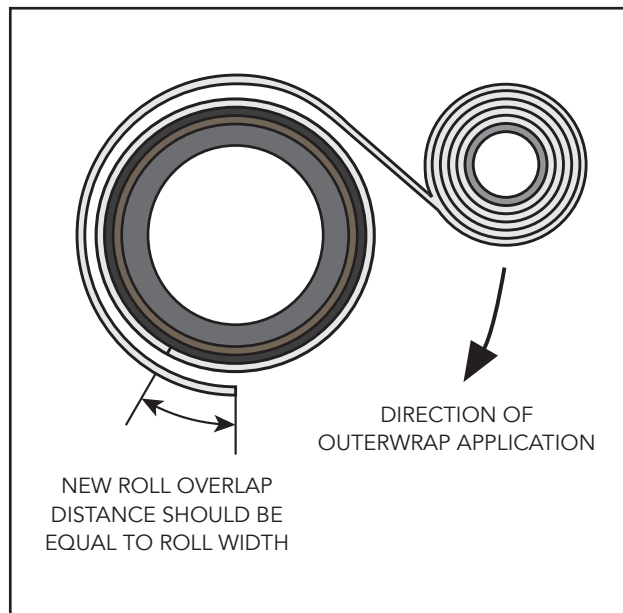

Fig. 13: Correct GOW application procedure.

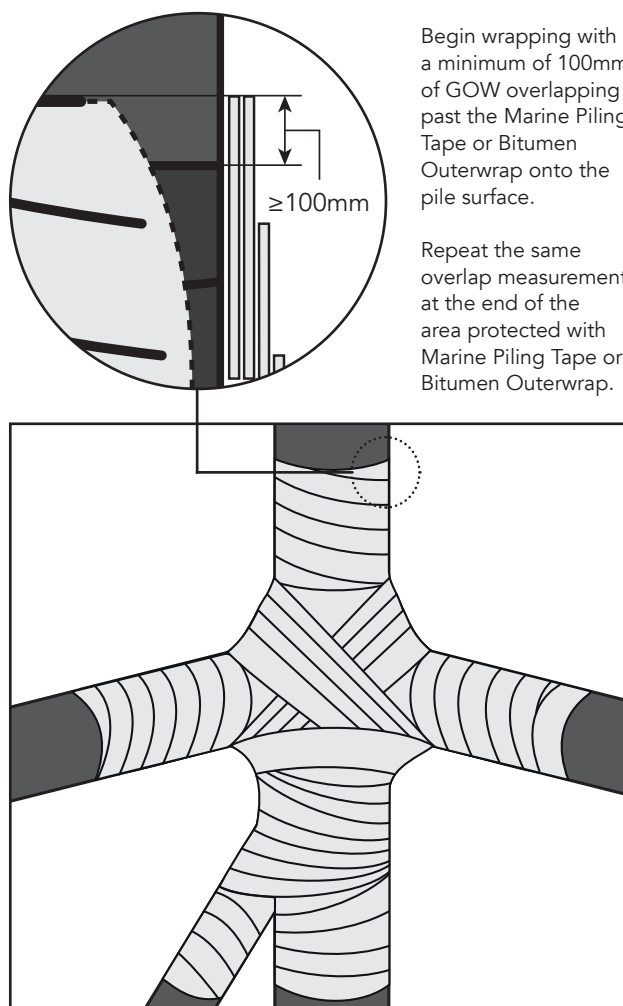

Fig. 14: Completed Glass Outerwrap application.

The GOW shall be compressed during the curing process using the following method.

Several layers of Clear Outerwrap shall be applied with tension over the GOW (see Fig. 15). These layers of Clear Outerwrap shall be perforated using the Perforation Tool. Once the GOW has cured (approximately 30 minutes at 25°C) the Clear Outerwrap can be removed by hand. Additional compression may be achieved using PVC Self Adhesive Tape as required (see Fig. 16).

The GOW shall be inspected to ensure it has been wrapped with the specified 55% overlap, that large air bubbles (greater than 25mm across) are excluded from under the GOW and that all overlaps are sealed together.

If the SeaShield 70/80 System is applied in conjunction (on the same pile) with another SeaShield System, the SeaShield 70/80 System shall be overlapped onto the other SeaShield System or the other SeaShield System onto the SeaShield 70/80 System by 50mm (see Fig. 17).

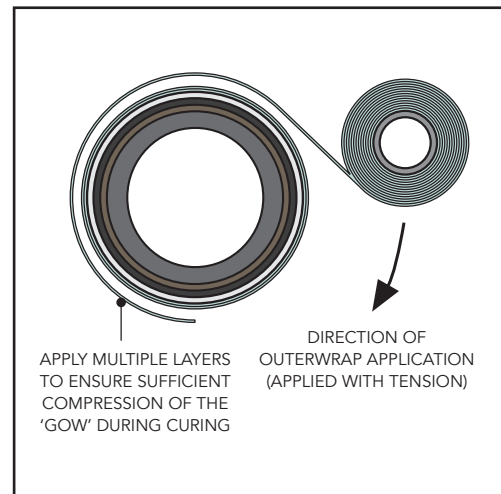

Fig. 15: Correct Clear Outerwrap application procedure.

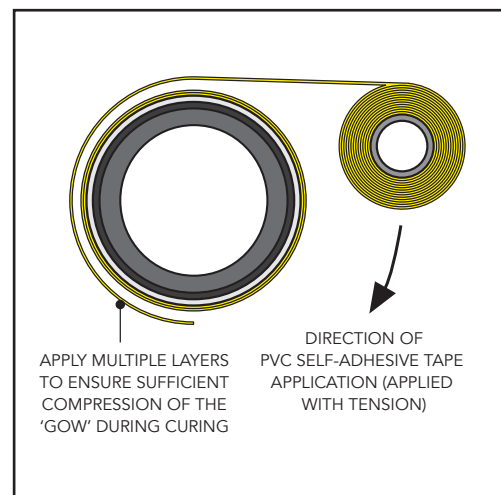

Fig. 16: Correct Self-Adhesive Tape application procedure.

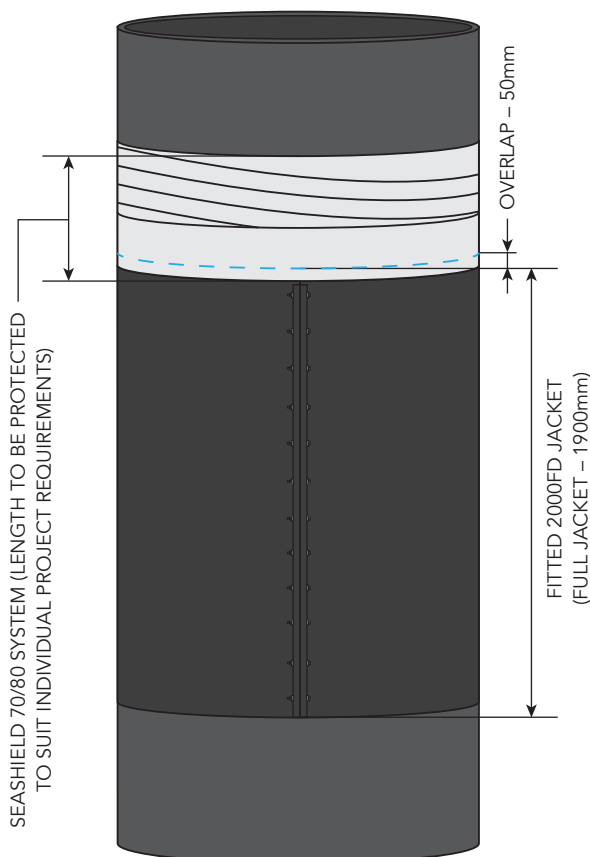

Fig. 17: SeaShield 70/80 System and SeaShield 2000FD System applied to the same pile.